

# Sellenis S-Jet 600

The new, reliable, high speed range of Industrial digital printers  
using the well tried, tested and trusted HP TU 2.5 technology





**A full range  
of printer models to meet  
your industrial digital printing  
needs**

A full range of printers tailored to meet your various Coding, Marking & Product ID applications needs. With the S-Jet 600 series you do not have to compromise between what is on offer and your requirements. You choose the printer system that you need, not what is available...print images from a maximum of 12.5 mm using a 1-pen printhead system to 100 mm in height, for an 8-pen printhead configuration.

You configure your printer as you wish from one to 4 pens combined in a single printhead or configured in groups of printheads to allow, for instance, for printing on different production lines using the same controller or for printing on different sides of, say a box, at the same time.



The S-Jet 600 Highly configurable. Offering versatility and flexibility

## On-line controller

The **S-jet 600** series printers have been designed to give the flexibility to locate the whole system (controller and print module(s)) on-line, on the production line. Alternatively, the controller can be located off-line, away from the production line and the print module.

In this latter configuration, the set up and the printing is controlled from an office or an off-line where the controller is situated. Furthermore, the controller can be one of Sellenis' controllers or a PC incorporating Sellenis' S-Jet 600 series software.

The configuration shown here in the attached photo is that of an on-line configuration in which the whole printing system is located on or next to the production line. The printheads are connected to the controller by cables. The controller incorporates both the GUI and the Print Engine Driver Board.



## Off-line controller

**Highly configurable.  
Offering versatility and flexibility**

The S-jet 600 series printers have been designed to operate using sellenis dedicated controller or alternatively sellenis' controller software installed and running on your own PC or laptop. In any of these configurations the controller, your pc or laptop are simply connected to the Print Engine Interface system using a standard Ethernet cable.

In any of these configurations, the Print Engine Interface system and the print module (s) will located near or on the production line but the controller, laptop or PC can, if necessary, be located far from the production line in an office somewhere in the factory or even in a different city or country altogether.





Offering superior print quality at up to 600 dpi resolution of alphanumeric texts, variable data, barcodes, graphics and logos up to 100mm high at speeds of up to 5 m/s

Complete range of no mess coding & marking ink jet printers from 1 printhead up to 8 printheads module systems

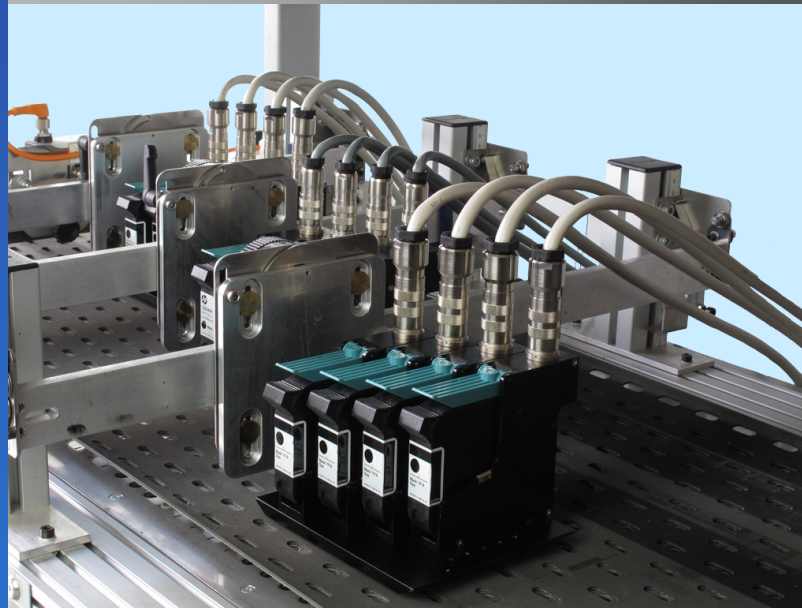

- Economical
- Versatile
- Easy to use
- Optional vision system for print & verify; Track & Trace
- Easily integrated with existing systems



## Are you Serialisation ready?

**With the S-Jet 600 you will be fully compliant with current and pending legislations**

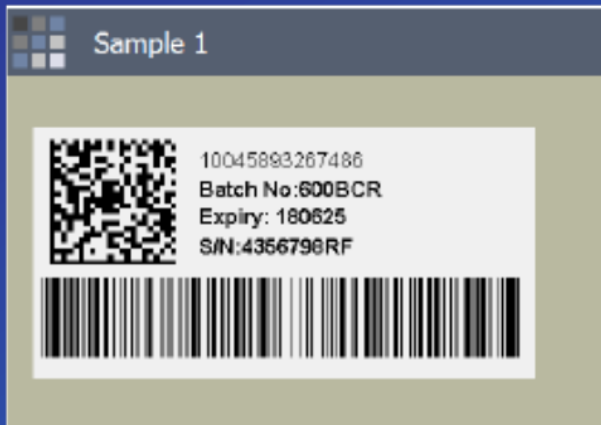

The S-Jet 600 series incorporates a powerful printer controller and associated software. This allows you to implement and meet the various health and safety legislations that are in force or pending introduction around the world. These legislations include the serialisation and the coding of medicines, cosmetics, cigarettes and other products to prevent dangerous counterfeit and diversion both for health and safety and brand protection purposes. Don't get caught unprepared, stay ahead.

These legislations are real, increasing and will force manufacturers to serialise their products to enable their traceability throughout the supply chain. Manufacturers can face fines or even be ordered to stop production if they do not comply. Sellenis controller software is serialisation ready. It incorporates powerful and secure serialisation that support GS1 data format and comply with FDA 21CFR part 11, and CIP

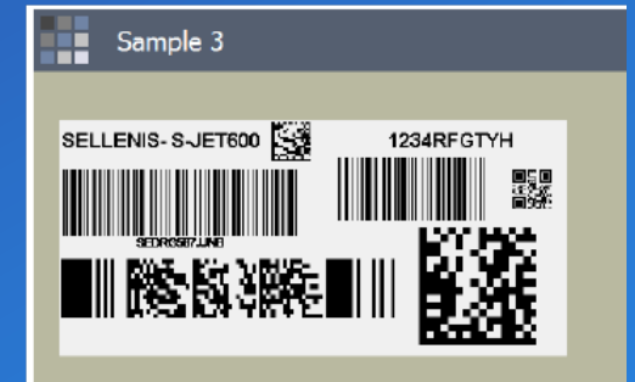

The S-Jet 600 series delivers high quality, 600 dpi barcodes ensuring 100% scan ability and readability every time. No failure, no error, no waste. The S-Jet600 comes with powerful serialisation ready software and offers a full range of 1D and 2D barcodes including QR code; Datamatrix; PDF 417; Databar; Aztec; Micro QR code and Micro PDF 417



## A range of robust, durable high quality print modules

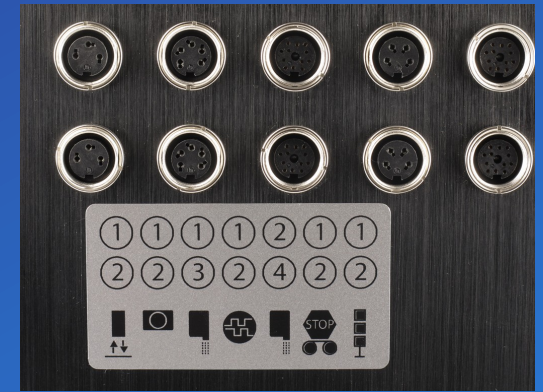

Extended connectivity



# Coding, marking and product ID

Versatility, flexibility, configurability and more...

## Sellenis S-Jet 600 series

**Sellenis S-Jet 600 gives you ....**

.....more productivity-high uptime

.....more print quality - up to 600 dpi

.....more flexibility -print text, images, logos, 1D 2D barcodes,  
up to 100 mm high

.....more applications including pharmacy, blister packs,  
cosmetics, cigarettes

.....Higher throw distance up to 5mm

.....more profit

Sellenis S-Jet 600 printer is the new gold standard for your high quality, secure, error free product coding, marking and auto ID jobs... no other ink jet printing technology can come even close.

**Enabling you to apply correct codes; implement Serialisation to meet increasing track & trace legislations**

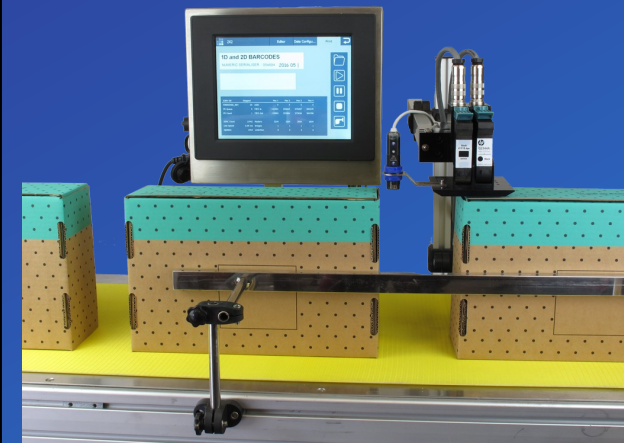
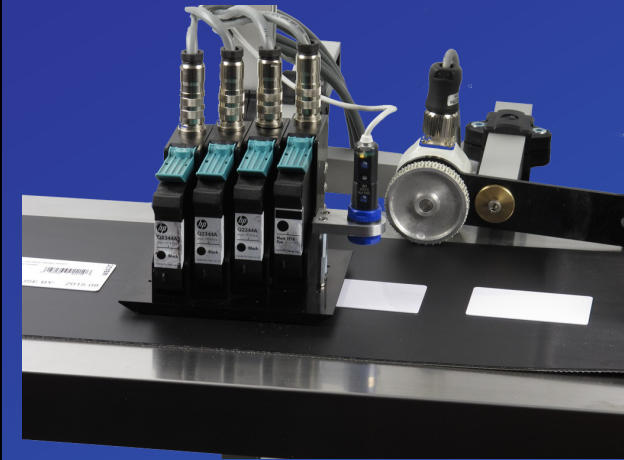

## Easy, expandable integration

### Communication interface:

- USB 2;
- 100/10M Ethernet;
- or 100M WiFi Ethernet;

### Machine External Interface port:

- 2X photocell;
- 2x Shaft Encoder;
- 2x Relay port drive 4 Relay;
- 2x Lamp Beacon ports;
- 2x Camera Port or Photocell loop back port;

### Print Head drive interface;

- 4x independent print head interface port
- 8x independent print head interface port

## Powerful features for Product Identification, Serialisation & Track & Trace

- Touch screen user interface.
- Full sets of latest 1-D and 2-D barcodes for Track and Trace.
- Support for GS1 formatted data
- Multiple security level access.
- Compliance with FDA 21CFR part 11, CIP,
- Allows you to print unique PIN codes
- Implement secure Serialisation schemes to meet 21CFR part 11, CIP,
- Counters
- Shifts & batch codes
- Fully configurable text and images supported on a Windows Embedded platform.
- Variable data.
- Modular grouping of pens with independent configuration of orientation and printed image length.

## Applications:

- Coding & Marking
- Serialisation and Track & Trace
- Product ID
- Medicines , pharmaceuticals packaging (primary, secondary, tertiary)
- Cigarettes
- Cosmetics

# Sellenis S-Jet 600 series

## Flexibility, expandability, simple to install; just plug it and run it

- Can print on metals, plastics, woods, flexible films, PVC, polypropylene, foil blister packs, pharmaceutical, medicine packaging, carton boxes, woods,
- Barcode, logos, texts, graphics up to 100 mm (4") high
- Track & trace with vision system
- Several printer system configurations to suit application

## Unmatched TCO and environment friendly operation

- Practically maintenance free
- No ink mess, no printhead flushing, cleaning or drying ....all these traditional ink jet , tedious operations are all gone
- No washdown down waste that you have to put up with using traditional ink jet ...With the S-Jet 600 TIJ all this waste becomes history. A thing of the past.
- No sticking of labels process and labour requirement – printing occurs on line at speed hence improved productivity
- No make-up consumption and no solvent evaporation -- - you help the environment and your reduce running costs
- No solvent recovery expenses (such as peltiers);
- No MEK vapour fume removal schemes and extra expense
- No more scheduled maintenance and associated expensive service contracts
- No hazardous materials or containers to handle, manage and dispose of

## Outstanding performance

A range of printers using a technology you can rely upon

- Resolution 600x600 dpi
- Print speed up to 150 m/min or 500 ft/min
- Print height up to 100 mm (4")
- Throw distance up 5 mm
- Print on a wide variety of substrates- including plastics, metals, woods, carton boxes, aluminium and pharmaceutical blisters pack
- Practically maintenance free

# Sellenis S-Jet 600 series

| Print Features                      |  |
|-------------------------------------|--|
| <b>Throw distance</b>               | Up to 5 mm   |
| <b>Print coverage</b>               | Up to 100 mm high  |
| <b>Fixed and variable bar-codes</b> |  |
| <b>1D Barcodes</b>                  | A full, comprehensive list of 1D barcodes                                  |
| <b>2D Barcode</b>                   | QR code; Datamatrix; PDF 417; Databar; Aztec; Micro QR code; Micro PDF 417 |
| <b>Support full GS1 format data</b> | Yes  |
| <b>Graphics &amp; Logos</b>         | Yes  |
| <b>Variable data</b>                |  |
| <b>Numeric serialisers</b>          | Yes  |
| <b>Date and time stamps</b>         | Yes  |
| <b>Shift codes</b>                  | Yes  |
| <b>User codes</b>                   | Yes  |
| Substrates                          |  |
| <b>Porous – absorbent</b>           | Yes  |
| <b>Non porous – non absorbent</b>   | Yes  |
| <b>Coated</b>                       | Yes  |
| <b>Non-coated</b>                   | Yes  |
| <b>Paper</b>                        | Yes  |
| <b>Plastics</b>                     | Yes  |
| <b>Metals</b>                       | Yes  |
| <b>Pharmacy blister packs</b>       | Yes  |
| <b>Woods</b>                        | Yes  |

| Print specifications                                    |                             |            |               |
|---|-----------------------------|------------|---------------|
| <b>Quality</b>  |                             |            |               |
| <b>Technology</b>                                       | HP TIJ 2.5 Thermal Ink Jet  |            |               |
| <b>Vertical resolution</b>                              | 300 or 600 dpi              |            |               |
| <b>Horizontal Resolution</b>                            | 150, 200, 300, 450, 600 dpi |            |               |
| <b>Fonts</b>  | Multiple fonts              |            |               |
| <b>Colour</b>   | Monochrome                  |            |               |
| Print speeds (dependent on horizontal print resolution) |                             |            |               |
|   | <b>m/min</b>                | <b>m/s</b> | <b>ft/min</b> |
|   | 38                          | 0.6        | 120           |
|   | 52                          | 0.85       | 170           |
|   | 78                          | 1.3        | 260           |
|   | 116                         | 1.9        | 380           |
|   | 155                         | 2.5        | 520           |
|   | 306                         | 5.1        | 1020          |



| <b>Connectivity</b>  |  |
|--|--|
| <b>Controller</b><br>Windows 7 or 8<br>Import , export data via USB devices or Ethernet<br>Touch screen GUI<br>Or keyboard/Mouse   | <b>Communication interfaces:</b><br>USB 2;<br>100/10M Ethernet;<br>or 100M WiFi Ethernet                                   |
| <b>Machine External Interface port:</b><br>2x Photocell;<br>2x Shaft Encoder;<br>2x Relay port drive 4 Relay;<br>2x Lamp Beacon ports;<br>2x Camera Port or Photocell loop back port | <b>Print Head drive interface;</b><br>4x independent print head interface port<br>8x independent print head interface port |
| <b>Production lines</b><br>Can print simultaneously on 2 independent production lines  |  |

| <b>Accessories</b>                    |
|---------------------------------------|
| Photo-cell Retro-reflective assy      |
| Lamp stack assy Lights only           |
| Lamp stack assy with alarm            |
| Shaft encoder kit wheel version       |
| Shaft encoder kit motor shaft version |
| Shaft encoder                         |
| Shaft encoder wheel                   |
| Alarms Kit                            |
| Camera cable assy                     |
| Camera cables                         |
| Print Head cable extension 1          |
| Lamp stack cable extension            |
| Camera cable extension                |
| Photo-cell cable extensions           |
| Shaft encoder cable extension kit     |



## Integrated controller

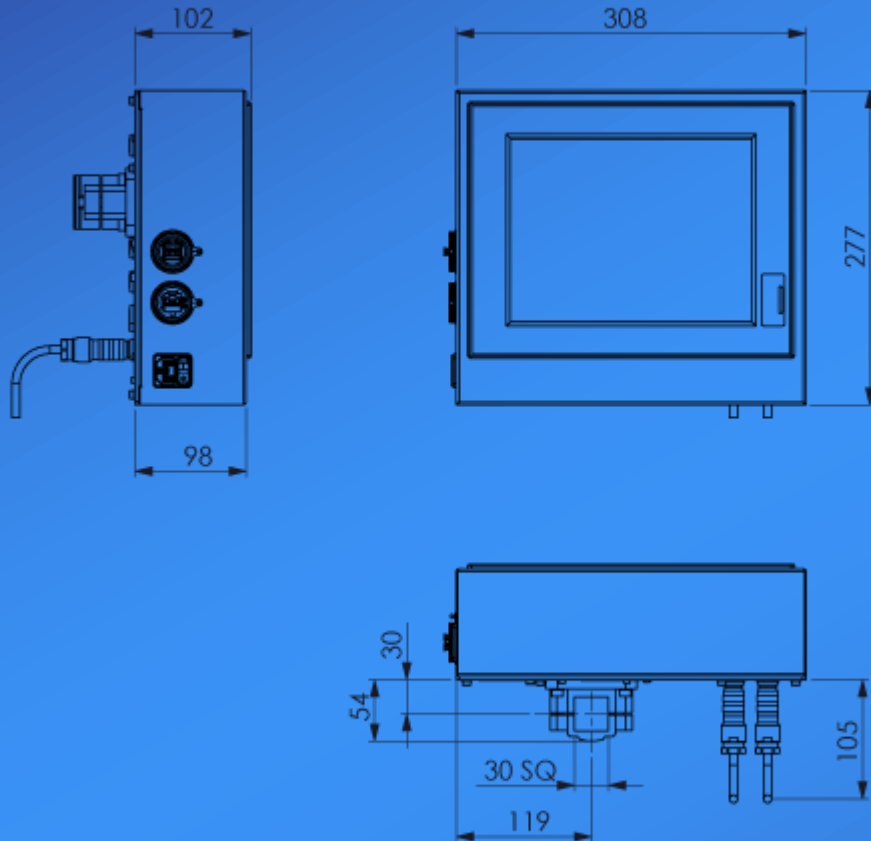

## Interface Module Driver

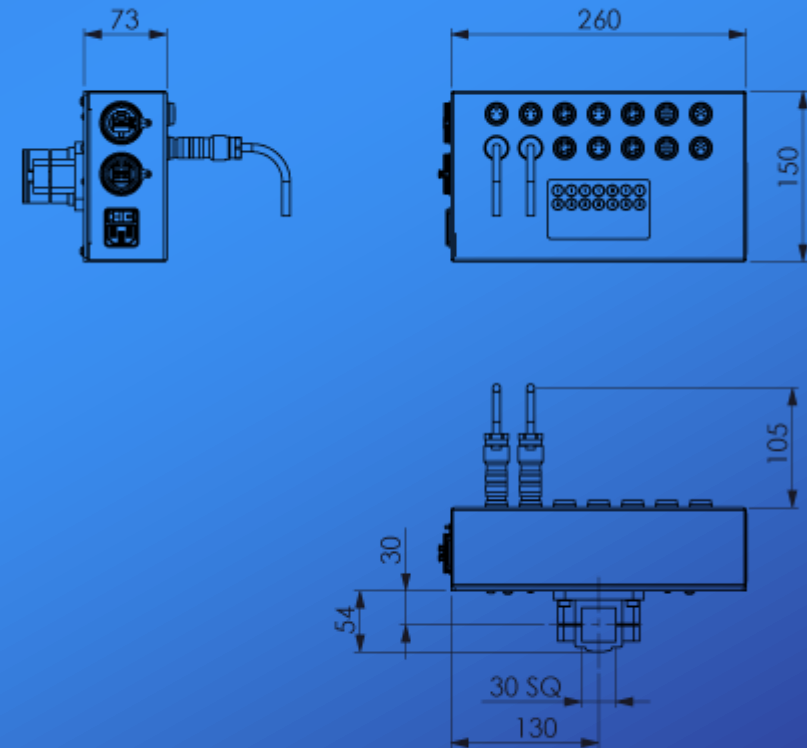

## 1 head print module

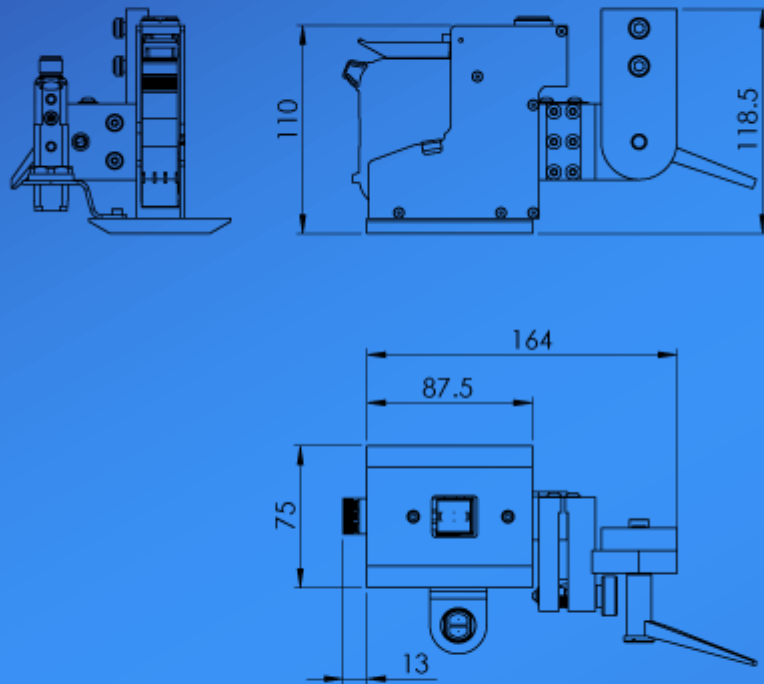

## 2 head print module

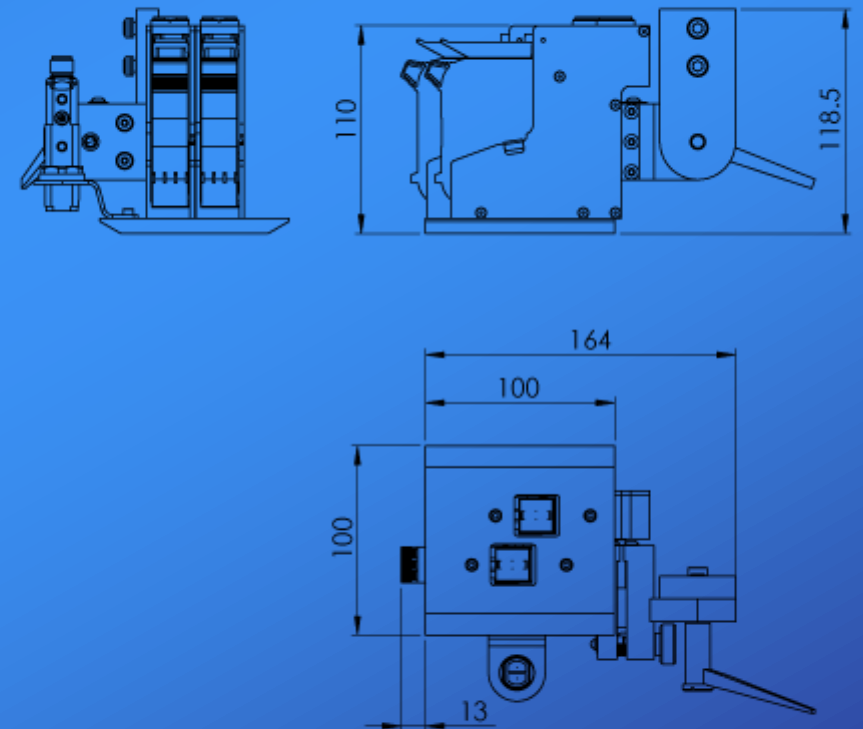

### 3 head print module

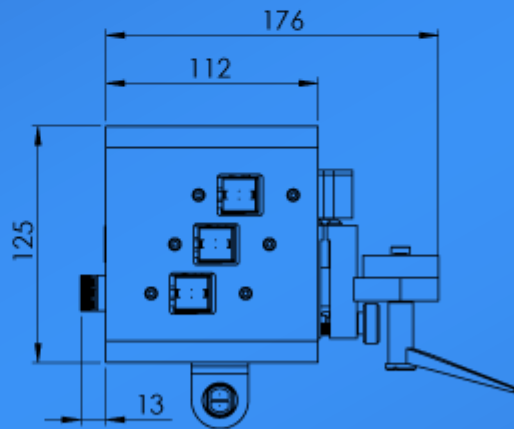
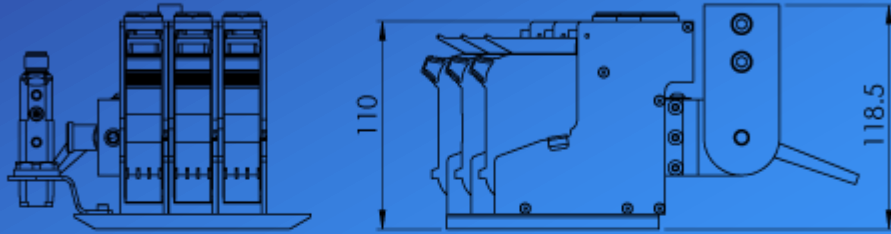

### 4 head print module

